

Investigation of the effects of a carbon-fiber tabletop on the surface dose and attenuation dose for megavoltage photon beams

G. GURSOY¹, E. ESER^{2*}, I. YIGITOGLU³, H. KOÇ⁴, F.C. KAHRAMAN⁵,
S. YAMCICIER¹

¹Department of Medical Services and Technical, Vocational School of Health Services, Ahi Evran University, Kırşehir, Turkey

²Department of Physics, Polatlı Faculty of Arts and Sciences, Gazi University, Ankara, Turkey

³Department of Physics, Faculty of Arts and Sciences, Gaziosmanpaşa University, Tokat, Turkey

⁴Department of Electrical and Electronics Engineering, Faculty of Engineering, Muş Alparslan University, Muş, Turkey

⁵Provincial Health Directorate, Isparta, Turkey

ABSTRACT

Background: Multiple beams are generally used with an increased possibility that the beam axis intersects the treatment table. Treatment tabletops are commonly made of carbon fiber due to its high mechanical strength and rigidity, low specific density, extremely light and low radiation beam attenuation properties. Purpose of this paper is investigated the dose changes in the buildup region and beam attenuation by a carbon fiber tabletop for high energy 6- and 18-MV photon beams. **Materials and Methods:** Measurements were performed for 10 cm × 10 cm and 20 cm × 20 cm field sizes. The surface dose and percentage depth doses (%DD) were measured by a Markus parallel plate chamber at a source-surface distance (SSD) of 100 cm for 6 MV and 18 MV photon beams. Attenuation measurements were made at the solid-water phantom for gantry angles of 0° and 180° rotation of the beam. **Results:** A carbon fiber tabletop increases the surface dose from 12.87% to 86.65% for 10 cm × 10 cm and from 8.72% to 71.16% for 20 cm × 20 cm field at 6 and 18 MV, respectively. The surface dose with the carbon fiber tabletop in an open field (0°) increases with field size. **Conclusion:** The carbon fiber tabletop causes a substantially increased surface dose, and also significantly decreases the skin-sparing effect, which is clinically important. The dosimetric effect of the tabletop may be higher, especially for the intensity-modulated radiation therapy depending on the beam orientation.

Keywords: Radiation, radiotherapy, carbon fiber tabletop, surface dose, buildup region.

► Original article

*Corresponding authors:

Dr. E. Eser,

Fax: +90 (312) 622 85 73

E-mail: eserphy@gmail.com

Revised: May 2017

Accepted: July 2017

Int. J. Radiat. Res., April 2018;
16(2): 235-241

DOI: 10.18869/acadpub.ijrr.16.2.235

INTRODUCTION

Carbon fiber is extremely light and strong with a low density and high rigidity ⁽¹⁾. In addition to these properties, carbon fiber has also been described as radio-transparent ^(1,2) for both kilovoltage and megavoltage photons. Therefore, carbon fiber materials are used widely in external beam radiotherapy for

providing patient support or immobilization. Contrary to the other materials used for treatment tables, one of most important advantages of the carbon fiber tabletop is the lack of gantry direction limitations. Despite the useful properties of carbon-fiber tabletops, they can be cause the beam attenuation. If the beam attenuation is not taken into account, this causes a lower dose delivered to the treatment volume.

For posterior and oblique irradiation fields, it is required that tabletops cause minimal attenuation of high-energy photon beams. The effect of the carbon-fiber tabletop on the beam attenuation has been reported by several researchers (3-8). A beam attenuation of 15% for a posterior oblique beam was measured by Viera *et al.* (4). Poppe *et al.* (5) measured an attenuation of 2.7% at a 0° gantry angle. Mihaylov *et al.* (9) measured an attenuation of 3.2% at a 0° gantry angle. Njeh *et al.* (8) found a beam attenuation of 3.4%.

As regards treatments involving posterior and posterior oblique irradiation fields, the other concern is the skin reaction with loss of the skin-sparing effect in the buildup region (5,6,10-12). Balosso *et al.* (13) proposed an approach to evaluation of the radiation tolerance of healthy tissues for high linear energy transfer. Wells *et al.* (10) suggested two prophylactic creams which helped to prevent skin reactions. It was shown by Higgins *et al.* (13) that the skin-sparing effect is reduced more for small field sizes than larger field sizes. To summarize, by considering the effect of tabletop on the dose distribution, one should take into account the dosimetric properties of the carbon fiber tabletops used during the planning process.

The aim of this study was to examine the effect of the carbon fiber tabletop on the surface dose and buildup region for various field sizes (10 cm × 10 cm and 20 cm × 20 cm) using 6MV and 18MV photon beams. Therefore, the surface and buildup region measurements were performed in the solid water phantom with a parallel plate ionization chamber.

MATERIALS AND METHODS

Dose measurement apparatus

All measurements were performed on radiation from a linear accelerator (Siemens-M5395) with a 41-leaf multi leaf collimator. Two different photon beams were used: 6 MV [quality index (QI) 0.671] and 18 MV [QI 0.771]. The carbon fiber tabletop used had dimensions of 50 cm × 190 cm × 7 cm with a

density of 1.8g.cm⁻³ (Reuther Medizintechnik GmbH&Co. KG, Mülheim- Karlich, Germany). The carbon fiber tabletop is hollow with a wall thickness between 0.6 and 0.8 mm (5,18). We also used an RW3 solid-water phantom (PTW (Physikalisch-Technische, Werkstätten) Freiburg, Germany) in the dimensions of 40x40 cm² with a density of 1.045 g.cm⁻³. The solid water phantom was used for measuring the surface dose in the phantom and in the buildup region. It consists of slabs with thicknesses of 1, 2, 5 and 10 mm.

A Markus parallel-plate chamber (PTW 34045) and a digital electrometer (PTW, Unidos T10008) were used for measurement the dose in the phantom surface and in the buildup region for the 6 MV and 18 MV photon beams. The Markus parallel-plate chamber was placed in direct contact with the surface of the phantom. The electrode spacing of the Markus chamber is 1mm, and the entrance window material is polyethylene of 0.03 mm thickness. The chamber is vented to the atmosphere; therefore, a density correction must be made for each measurement.

Measurement of depth dose

The depth dose and surface dose were measured for 10 cm × 10 cm and 20 cm × 20 cm field sizes at a source-surface distance (SSD) of 100 cm by changing the depth of the chamber in the phantom at gantry angles of 0° (figure 1) and 180° (figure 2). The entrance window of the Markus parallel-plate chamber was directed toward the source.

The percentage depth dose (%DD) was measured as the ratio of the absorbed dose in the depth to the maximum absorbed dose along the beam axis (15). Buildup curves were obtained for 6 MV and 18 MV beams at 10 cm × 10 cm and 20 cm × 20 cm field sizes. The measurements were made at the gantry angles of 0° (without the carbon fiber tabletop) and 180° (in the presence of the carbon fiber tabletop). The %DD measurement were taken from 0 to 200 mm using the solid water phantom of thicknesses of 1, 2, 5 and 10 mm at a source-surface distance of 100 cm. The %DD curves have been obtained for above mentioned

field sizes with the tabletop for the buildup region. The source-surface distance (SSD) was

arranged as 100 cm. The window of chamber was directed toward the source (figure 2).

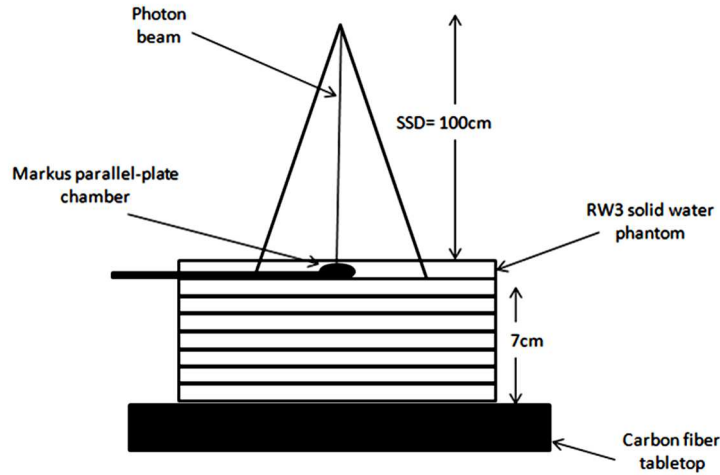

Figure 1. Experimental setup for measurement of the dose to the surface and buildup region for an open beam (0°).

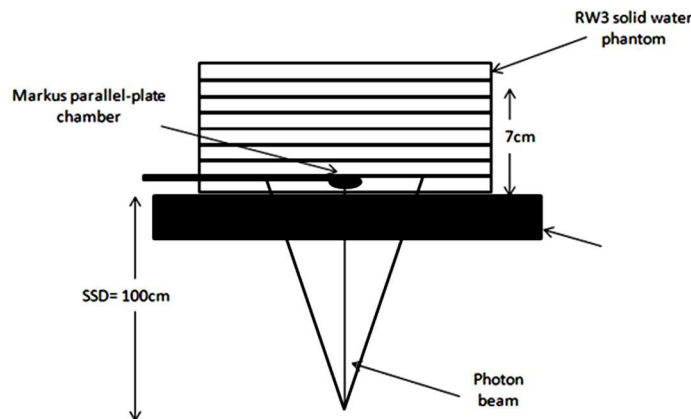

Figure 2. Experimental setup for measurement of the dose to the surface and buildup region for a carbon-fiber tabletop (180°).

These relative surface dose was calculated as the ratio of the absorbed dose at the surface to the maximum absorbed dose. For the Markus parallel-plate chamber, the fluency of the surface perturbation generally causes over-estimation of the surface dose (16-18). The Gerbi method (16) was used to correct this over-response in measured %DD at the buildup region (equation 1).

$$P'(d, E) = P(d, E) - \xi(d, E) \quad (1)$$

Where: $P'(d, E)$ is the corrected percentage depth dose, $P(d, E)$ is the measured depth dose, E is the energy, and $\xi(d, E)$ is the chamber correction factor for the energy of beam:

$$\xi(d, E) = \xi(0, E) e^{-\alpha(d/d_{max})} \quad (2)$$

$$\xi(0, E) = [-1.666 + (1.982/IR)] \times [C - 15.8] \quad (3)$$

where $\xi(0, E)$ is the energy-dependent chamber correction, l is the electrode separation (1 mm for this study), α is a constant, d is the depth from the surface to d_{max} , C is the sidewall-collector distance, which was 0.03 mm for the Markus chamber used, IR is the ratio of ionization measurement at 10 cm and 20 cm for 10 cm × 10 cm field sizes (IR for 6MV and 18 MV in this study are 0.671 and 0.771, respectively). Substituting equations (2-3) into equation (4), the simply structured formula can be obtained as follows:

$$P'(d, E) = P(d, E) - \xi(0, E) e^{-\alpha(d/d_{max})} \quad (4)$$

RESULTS

The percentage depth dose curves obtained for an open beam (0°) and the carbon fiber tabletop for 6 MV and 18 MV at 10 cm \times 10 cm and 20 cm \times 20 cm field sizes are shown in figures 3 and 4. Figures 5 and 6 also show the percentage depth dose (%DD) curves obtained from the different chambers (the extrapolation chamber, the Monte Carlo (MC) simulation, Markus chamber, the CC13 chamber and TLD chips) for 6 MV photon beam at 10 cm \times 10 cm and 20 cm \times 20 cm field sizes. Table 1 shows the surface dose measurements (at SSD= 100cm) made with different chambers for 6 MV and 18 MV photon beams in open fields.

The measurements show that the surface dose with the carbon fiber tabletop in an open field (0°) is field size dependent. The surface

dose with the carbon fiber tabletop increased from 82.84% (10 cm \times 10 cm) to 86.65% (20 cm \times 20 cm) for 6 MV and from 62.49% (10 cm \times 10 cm) to 71.16% (20 cm \times 20 cm) for 18 MV. The surface dose with the carbon-fiber tabletop increased almost seven fold for 10 cm \times 10 cm and nearly fourfold for 20 cm \times 20 cm. The measured values were always higher for 10 \times 10 cm² field than for 20 \times 20 cm² fields, in the same measurement conditions. As expected, all measurement shows also higher attenuation values as the gantry angle increases ⁽³⁾.

In literature, although several studies have reported on the carbon fiber tabletop support beam attenuation, none is not including comparisons by different chambers. With this study, the attenuation of the tabletop was compared and was shown which the chamber is more suitable for treatment planning.

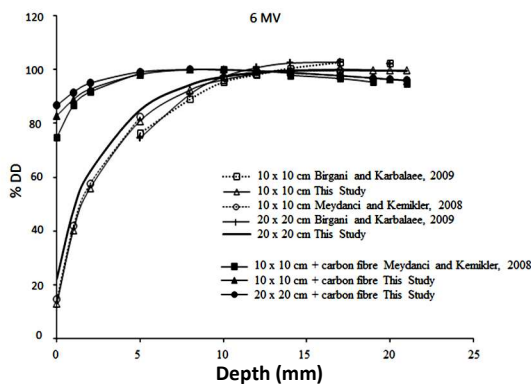

Figure 3. Percentage depth dose (%DD) curves with and without the carbon-fiber tabletop for various field sizes for a 6 MV photon beam.

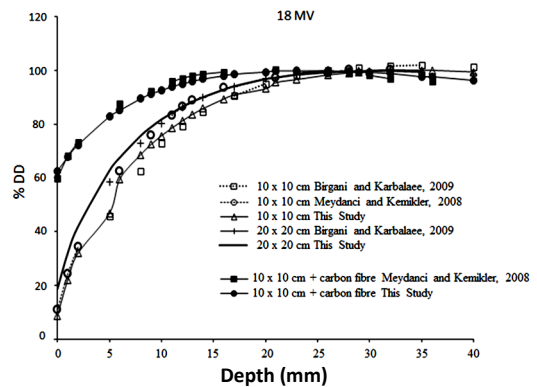

Figure 4. Percentage depth dose (%DD) curves with and without the carbon fiber tabletop for various field sizes for an 18MV photon beam.

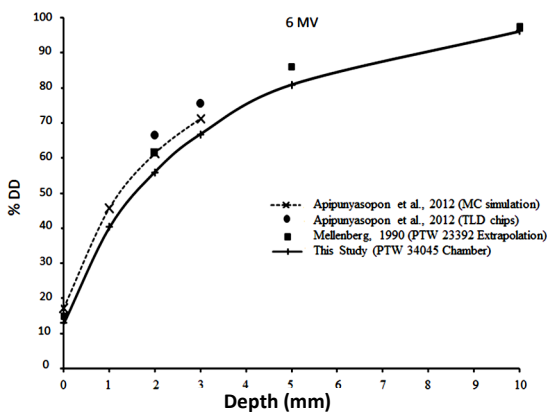

Figure 5. Percentage depth dose (%DD) curves obtained from different chambers for a 6MV photon beam at 10 cm x 10 cm field size.

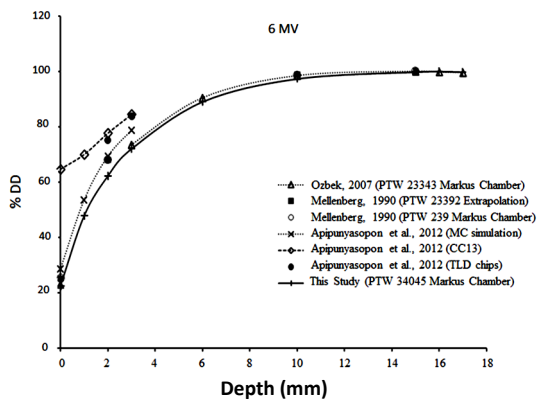

Figure 6. Percentage depth dose (%DD) curves obtained from different chambers for a 6-MV photon beam at 20 cm x 20 cm field size.

Table 1. Surface dose at source-surface distance = 100 cm for 6 MV and 18 MV photon beams in open fields.

References	Field size (10x10cm ²)		Field size (20x20cm ²)	
	6MV	18MV	6MV	18MV
Orchran et al. ⁽²⁴⁾	17.4	13	28.3	25
Özbek ⁽¹⁹⁾	15.4	10.6	22.9	21.7
Rapley ⁽²⁰⁾	16	-	-	-
Cheng et al. ⁽²¹⁾	18.8	-	-	-
Li and Klein ⁽²²⁾	12.8	14	24.5	28.4
Meydanci and Kemikler ⁽¹⁸⁾	14.5	10.9	-	-
Mellenberg ⁽¹⁷⁾	14.9	14	25	27.7
Gerbi and Khan ⁽¹⁶⁾	15.2	-	-	-
This study	12.8	8.7	22.2	18.7

DISCUSSION

The accuracy of the dose measurement and distribution in radiation treatment planning (RTP) for high-energy photon beams plays a very important role because it must be consistent with the dose distribution in the irradiated volume. However, the surface dose cannot easily be measured or evaluated. Accurate dose measurements for photon beams is difficult but important task. Although the extrapolation chamber is specially designed to measure the dose at the surface and buildup region, the use of parallel plane chambers⁽¹⁶⁾ and radio chromic films⁽²⁵⁾ is more common.

In this study, we used the parallel-plate chamber to measure the dose in the phantom surface and in the buildup region for high-energy photon beams.

As previously reported, the buildup and surface doses increase with field size. The surface dose increased from 12.87% (10 cm × 10 cm) to 22.27% (20 cm × 20 cm) for 6 MV and from 8.72% (10 cm × 10 cm) to 18.73% (20 cm × 20 cm) for 18 MV. The cause of the increase in the surface dose with field size is the contaminating electrons from collimators, phantom surface, flattening filter, treatment head. Therefore, as stated previously, it is important to measure the dose at the surface and in the buildup region to do accurate treatment planning.

When a carbon-fiber tabletop is used, we can say that the surface dose increases and the depth of the maximum dose changes toward the surface for all field sizes and all photon energies.

The surface dose with the carbon fiber tabletop in an open field (0°) increases with field size. The surface dose with the carbon fiber tabletop increased from 82.84% (10 cm × 10 cm) to 86.65% (20 cm × 20 cm) for 6 MV and from 62.49% (10 cm × 10 cm) to 71.16% (20 cm × 20 cm) for 18 MV. The surface dose with the carbon-fiber tabletop increased almost seven fold for 10 cm × 10 cm and nearly fourfold for 20 cm × 20 cm.

The carbon-fiber tabletop increased the skin dose about twofold for 6 MV and 18 MV photon beam energies at 1mm depth. For example, the values obtained with and without the carbon fiber tabletop at the 10 cm × 10 cm field for 6MV photon beam were 40.31% and 88.86%, respectively. With the carbon-fiber tabletop acting as a bolus⁽¹⁸⁾, the depth of the maximum dose also changed from 36 mm to 16 mm and from 24 mm to 8 mm with the carbon-fiber tabletop for 6 MV and 18 MV, respectively (at 10 cm × 10 cm and 20 cm × 20 cm field sizes). Besides, at 20 cm × 20 cm field size, the depth of the maximum dose decreased with the beam energy increased. It is seen from the obtained results that the carbon-fiber tabletop cause an important increase in the skin dose, and the skin-pairing effect was reduced. As it is shown in figures 3-4 and Table 1, our results for 6 MV and 18 MV beam at all field sizes are in good agreement with other published data in the literature⁽¹⁶⁻²²⁾.

Figures 5-6 show the percentage depth dose (%DD) curves obtained from the different chambers for 6 MV photon beam. For the 10 cm × 10 cm field size, it is shown in figure 5 that our

results near the surface are in better agreement with the results of the extrapolation chamber rather than the Monte Carlo (MC) simulation. At a depth of 0 mm, our and other results are 12.9%, 14.9 for the extrapolation chamber ⁽¹⁶⁾ and 17.2% for the MC simulation ⁽²²⁾. Near the surface for the 20 cm × 20 cm field size, it is shown in figure 6 that the measurement obtained by using the CC13 chamber and TLD chips are different than our results while the data obtained for the different model of Markus chamber is in agreement with each other and the MC simulation.

This means that a reliable measurement of the percentage depth dose beyond the buildup region can be made with any the Markus chambers, and the measurement in the buildup region is dependent on the choice of detector. Because the CC13 detector had a large sensitive volume and is made of non-water equivalent material (which causes an over-response in the surface region), the CC13 chamber is not recommended for the surface dose measurements unless the correction factor for this chamber is available ⁽²³⁾.

As expected, the measured buildup and surface doses show an increase as the field sizes increases. This is usually due to the increase of scattered electrons in the air and collimator. As shown in table 1, the surface dose obtained for 6 MV at 20 cm x 20 cm field size (for open field) is close to of Özbek ⁽¹⁹⁾, Mellenberg ⁽¹⁷⁾, and Li and Klein ⁽²²⁾. At a 10 cm x10 cm field size, Özbek ⁽¹⁹⁾ found that the surface doses for 6MV and 18 MV were 15.4% and 10.63%, respectively. Li and Klein ⁽²²⁾ reported 12.8% and 14% surface doses for same field size and photon energies.

CONCLUSION

The obtained results showed that the carbon fiber tabletop may cause a substantially increased surface dose, while the skin-sparing effect decreases significantly. The carbon-fiber tabletop decreases the isocenter dose between 1.5% - 3.0%, depending on the gantry angles for 6 MV and 18MV photon beams.

Consequently, it was shown that the variation of the tabletop attenuation as a function of the gantry angle can be clinically important, and the beam attenuation of the carbon-fiber tabletop at the time of treatment planning also should be considered and corrected for any material.

Conflicts of interest: Declared none.

REFERENCES

1. De Mooy LG (1991) The use of carbon fibers in radiotherapy. *Radiotherapy and Oncology*, **22**: 140–142.
2. Bratengeier K, Baur W, Baier K, Wulf J, Flentje M (2004) A table top suited for CT and radio-therapy. *J Med Phys*, **14**: 118-122.
3. Silva C, Mateus D, Vieira S, Rodrigues M, Eiras M, Greco C (2016) Radiotherapy couches: is kevlar an obstacle? Attenuation study of three different tabletops. *Journal of Radiotherapy in Practice* **15**: 346–353.
4. Vieira SC, Kaatee RS, Dirkx ML, Heijmen BJ (2003) Two-dimensional measurement of photon beam attenuation by the treatment couch and immobilization devices using an electronic portal imaging device. *Med Phys*, **30**: 2981–2987.
5. Poppe B, Chofor N, Rühmann A, et al. (2007) The effect of a carbon-fiber couch on the depth-dose curves and transmission properties for megavoltage photon beams. *Strahlenther Onkol*, **183(1)**: 43–48.
6. McCormack S, Diffey J, Morgan A (2005) The effect of gantry angle on megavoltage photon beam attenuation by a carbon fiber couch insert. *Med Phys*, **32**: 483e7.
7. Gerig LH, Niedbala M, Nyiri BJ (2010) Dose perturbations by two carbon fiber treatment couches and the ability of a commercial treatment planning system to predict these effects. *Med Phys*, **37(1)**: 322–28.
8. Njeh CF, Raines TW, Saunders MW (2009) Determination of the photon beam attenuation by the Brainlab imaging couch: angular and field size dependence. *J Appl Clin Med Phys*, **10(3)**: 16–27.
9. Mihaylov IB, Corry P, Yan Y, Ratanatharathorn V, Moros EG (2008) Modeling of carbon fiber couch attenuation properties with a commercial treatment planning system. *Med Phys*, **35(11)**: 4982–88.
10. Wells M, Macmillan M, Raab G, et al. (2004) Dose aqueous or sucralfate cream affect the severity of erythematous radiation skin reactions? A randomized controlled trial. *Radiother Oncol*, **73**: 153-162.

11. Sigamani A, Nambiraj A, Yadav G, Giribabu A, Srinivasan K, Gurusamy V, Raman K, Karunakaran K, Thiyagarajan R (2016) Surface dose measurements and comparison of unflattened and flattened photon beams. *J Med Phys*, **41** (2): 85–91.
12. Wang Y, Khan MK, Ting JY, Easterling SB (2012) Surface dose investigation of the flattening filter-free photon beams. *Int J Radiat Oncol Biol Phys*, **83**: e281–5.
13. Balosso J (2004) Radiation tolerance of healthy tissues, high-LET beam particularities. *Radiother Oncol*, **73**: 141–143.
14. Higgins DM, Whitehurst P, Morgan AM (2001) The effect of carbon fiber couch inserts on surface dose with beam size variation. *Med Dosim*, **26**: 251–254.
15. Khan FM (2003) *The Physics of Radiation therapy* 3rd ed., Lippincott Williams and Wilkins, Philadelphia.
16. Gerbi BJ, Khan FM (1990) Measurements of dose in the build-up region on using fixed-separation plane-parallel ionization chamber. *Med Phys*, **17**: 17–26.
17. Mellenberg DE (1990) Determination of build-up region over-response corrections for a Markus-type chamber. *Med Phys*, **17**: 1041–1044.
18. Meydanci TP and Kemikler G (2008) Effect of a carbon fiber tabletop on surface dose and attenuation for high-energy photon beams. *Radiat Med*, **26**: 539–544.
19. Özbek N (2007) The research of effect of using wedge filters to surface dose in high energy photon beams. İstanbul University, Institute of Health Science, Department of Radiation Oncology. Master's Degree Thesis. İstanbul University, Turkey.
20. Rapley P (2006) Surface dose measurement using TLD powder extrapolation. *Med Dosim*, **31**(3): 209–215.
21. Cheng CV, Tang WL and Das IJ (2003) Beam characteristics of upper and lower physical wedge systems of Varian accelerators. *Phys Med Biol*, **48**: 3667–3683.
22. Li Z and Klein EE (1997) Surface and peripheral doses of dynamic and physical wedges. *Int J Radiat Oncol Bio, Phys*, **37**(4): 921–925.
23. Apipunyasopon L, Srisatit S, Phaisangittisakul N (2012) An Investigation of the depth dose in the build-up region, and surface dose for a 6-MV therapeutic photon beam: Monte Carlo simulation and measurements. *J Radiat Res*, **54**(2): 374–382.
24. Ochran TG, Boyer AL, Nyerick CE and Otte VA (1992) Dosimetric characteristics of wedges mounted beyond the blocking tray. *Med Phys*, **19**(1): 187–194.
25. Devic S, Seuntjens J, Abdel-Rahman W, Evans M, Ollivares M, Podgorsak EB (2006) Accurate skin dose measurements using radiochromic film in clinical applications. *Med Phys*, **33**: 1116–1124.

