

Dosimetric characteristics of ^{137}Cs sources used in after loading Selectron system by Monte Carlo method

M.B. Tavakoli, D. Shahbazi-Gahrouei*, M. Hosseinpour

Department of Medical Physics and Medical Engineering, School of Medicine, Isfahan University of Medical Sciences, Isfahan, Iran

Background: For an effective treatment planning in brachytherapy, it is necessary to know the accurate source dosimetric information such as air kerma strength, exposure rate constant, dose rate constant and radial dose distribution. The usual method to determine these factors is thermo luminescent dosimeter (TLD) dosimetry. Nowadays, another more accurate method is known to be the Monte Carlo simulation, and it is widely used in determining of brachytherapy sources dosimetric factors. The aim of the present study has been determine to dose distribution of ^{137}Cs sources configuration used in interacavitary low dose rate (LDR) Selectron brachytherapy by Monte Carlo simulation method.

Materials and Methods: Simulation has been performed for ^{137}Cs stainless-steel encapsulated source in 2.5 mm in diameter of Selectron system. Six different combinations of ^{137}Cs sources were simulated and each combination was put into different applicator. The Monte Carlo MCNP4C code was used for simulation. The number of history was taken 1 million for the calculation of air kerma strength and exposure rate constant and 0.1 million for calculating dose rate constant and radials dose distribution.

Results: Maximum air kerma strength was obtained for the combination with fourteen active sources and found to be $919.3 \mu\text{Gym}^2\text{h}^{-1}$ while its minimum value was $133.9 \mu\text{Gym}^2\text{h}^{-1}$ for the case with two active sources. Maximum and minimum dose rate constant of $4.3 \text{cGyh}^{-1}\text{mCi}^{-1}$ and $2.1 \text{cGyh}^{-1}\text{mCi}^{-1}$ were obtained for the combination with eight and fourteen active sources, respectively. **Conclusion:** The results indicated that the Monte Carlo simulation method may be useful to determine dosimetric characteristics of brachytherapy sources. Iran. J. Radiat. Res., 2007; 5 (3): 147-152

Keywords: ^{137}Cs , brachytherapy, radial dose, dose rate constant, Monte Carlo simulation.

delivering sufficient dose ⁽¹⁾. To have a successful treatment it is necessary to know the accurate information about sources dosimetric characteristic, such as air kerma strength, exposure rate constant, dose rate constant and radial dose distribution. Using TLD is a routine method for dosimetry ^(2, 3). Due to the small size of sources, using this method is difficult. Recently the Monte Carlo simulation method has been widely used for determining dosimetric characteristic in radiotherapy. Monte Carlo is the nominal method for solution or simulation complex problems in physics and mathematics ⁽⁴⁾.

During the recent years, a number of investigators have used this method to determine dosimetric characteristics of brachytherapy sources. Perez *et al.* ⁽⁵⁾ worked on two types of afterloading brachytherapy sources of CDC-1 and CDC-3 manufactured by Amersham Company. The obtained dose rate constant for the first source was $1.13 \pm 0.003 \text{cGym}^2\text{h}^{-1}$ and was $1.103 \pm 0.003 \text{cGym}^2\text{h}^{-1}$ for the second ⁽⁵⁾. Casal *et al.* ⁽⁶⁾ worked on CDCS-M-type source used in LDR afterloading system and obtained the dose rate of $0.946 \pm 0.007 \text{cGym}^2\text{h}^{-1}$ around the source. Williamson *et al.* ⁽⁷⁾ worked on dose distribution around two types of ^{137}Cs sources (3M6500, CDCS.J). They used the Monte Carlo MCPT code for simulation. This code can be used only for photon transport in a medium. They have found the dose rate to be constant for the two sources $0.978 \text{cGym}^2\text{h}^{-1}$

INTRODUCTION

Brachytherapy is a method of tumors treatment, in which radioactive sources are placed at a short distance of tumor cells to

*Corresponding author:

Dr. Daryoush Shahbazi-Gahrouei, Dept. of Medical Physics and Medical Engineering, Isfahan University of Medical Sciences, Isfahan, Iran.

Fax: +98 311 6688597

E-mail: shahbazi@med.mui.ac.ir

and 0.973 cGy^mh⁻¹, respectively. They compared their results with the results from TLD dosimetry, and found an error of %5 (7). In this study, the MCNP4C (Monte Carlo N-Particle version 4C) was used to calculate the dosimetric characteristics around the ¹³⁷Cs sources used in a Selectron LDR, afterloading system being installed in Seyed Al-Shohada hospital of Isfahan (Iran).

MATERIALS AND METHODS

¹³⁷Cs sources and applicator

In Selectron LDR afterloading system (Nucletron, installed in Seyed Al-Shohada hospital of Isfahan), radioactive sources were stored in a shielded container. After adjusting the applicator, ¹³⁷Cs sources and steel dummies could be driven into the stainless-steel applicator with 2 mm thickness. Dummies were used to produce a proper source distribution in the applicator to obtain suitable dose distribution in the treatment volume. In each setup, maximum of 48 ¹³⁷Cs sources and dummies could be driven in the applicator. A cross section of the after loading applicator is shown in figure 1.

Spherical ¹³⁷Cs sources consisting of two parts: The first part is internal active core with 1.5 mm in diameter and stainless-steel outer shell with 1 mm thickness. Diagram of a radioactive ¹³⁷Cs source is shown in figure 2.

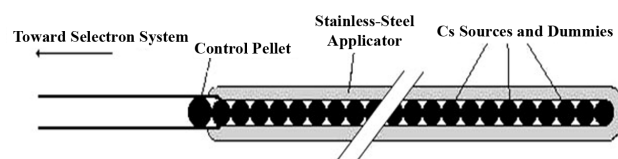

Figure 1. LDR afterloading Selectron applicator.

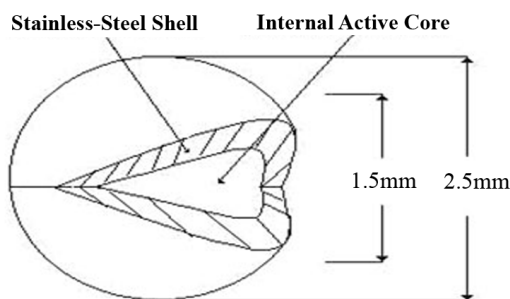

Figure 2. LDR afterloading Selectron ¹³⁷Cs source.

The second part is internal active core of ¹³⁷Cs source which has a special combination as shown in table 1.

Table 1. Radioactive ¹³⁷Cs source and shell media.

Component	Percentage of atomic composition	Density (g/cm ³)
Radioactive Cs source	Si (26.2%), Ti (3%), Al (1.6%), B (3.7%), Mg (1.2%), Ca (2.9%), Na (12.6%), Cs (1%), O (47.9%)	2.9
Stainless-Steel Model AISI 316L	Si (2%), Cr (20%), Mn (2%), Fe (67%), Ni (9%)	8.02

Holder

To fixing the applicator in the vagina, a special holder was used. Holders have cylindrical shape made of tissue equivalent material such as plexy-glass or polyethylene. For Selectron LDR afterloading brachytherapy system, there were several holders with different diameter (2, 2.5, 3, 3.5, 4, 4.5 cm) used for different patient sizes.

Monte Carlo simulation code

Monte Carlo method was used to solve complex problem in particle transport (8). The MCNP4C code was performed to simulate the mentioned brachytherapy source. The MCNP4C code enabled the simulation particle transport by getting problem information such as problem geometry, source particle energy distribution and materials. MCNP4C could also calculate various quantities such as particle flow passing surface, energy flow passing surface and energy releases in medium. The simulations were carried out on a Pentium[®] V computer with 128 MB RAM.

¹³⁷Cs sources setup in applicator

Because of different tumor sizes and positions, different sources and dummies arrangement were performed. The dummies arrangement is shown in table 2.

Phantom and dose calculating volume

Because of cylindrical symmetry of applicator, cylindrical phantom was used for

all simulations. A cylindrical water phantom of 30 cm in radial and 20 cm in length was selected to calculate the radial dose and dose rate constant. For calculating of air kerma strength and exposure rate constant, a cylindrical air phantom (105 cm in radial and 20 cm in length) was also used. As mentioned earlier because of cylindrical symmetry, a cylindrical volume was used to score the dose in any point as shown in figure 3.

As seen in figure 3, r is distance of calculating point from applicator axis. The values of Δr and Δz, for radial dose and dose rate constant, were 1 mm and 2 mm, respectively (9). Values of r, Δr and Δz, for air kerma strength and exposure rate constant were also 1 m, 1 mm and 2 mm, respectively.

Table 2. Different sources and dummies setup in applicator.

Setup number	Holder diameter Φ (cm)	Number of active sources	Sources and Dummies setup †
1	2.0	2	○●○
2	2.5	3	○●●○
3	3.0	4	○●●●○
4	3.5	8	○●●●●●●○
5	4.0	10	○●●●●●●●○
6	4.5	14	○●●●●●●●●●○

† ● indicate the active source and ○ indicate the dummy

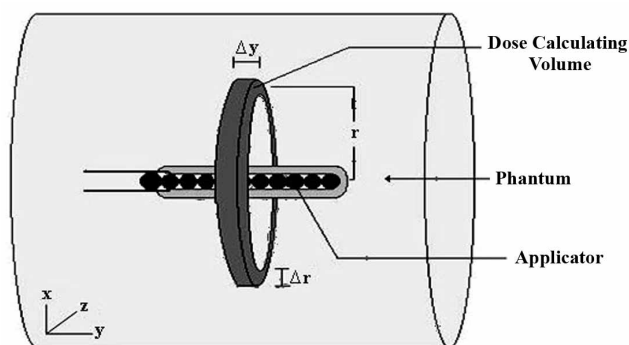

Figure 3. Three-D shape of phantom and dose calculating volume.

Tally and simulation setup

In MCNP4C code any output parameter is named *Tally*. There are different tally for different out put parameter in MCNP4C code. In this study, to calculate radial dose

and air kerma strength *f4 and f6 tally were used, respectively. The energy released in the medium (MeV/g), and the energy flow (MeV/cm²) were calculated using *f4 and f6 tallies. The absorbed dose at each position was obtained by multiplying *f4 tally by the mass energy-absorption coefficient in water. Mass energy absorption coefficients were obtained from Hubbell tables (10).

Photon energy for ¹³⁷Cs was to be 0.662 MeV. Photon interaction simulated includes pair production, photoelectric, compton scattering, and production of K-edge characteristic X-ray. The cut-off energy for both electron and photon in all calculations was 10 KeV. The value was the optimum quantity when pilot study was performed.

The number of assumed particle emitted from sources in radial dose was 100000, and for air kerma strength it was 1000000. For the mentioned parameters the Monte Carlo statistical error in representing calculation was under %1 and %3, respectively.

To measure the accuracy in all Monte Carlo simulation, it was necessary to compare the obtained result with TLD data dosimetry. TLD dosimetry data were obtained from manual of the Selectron of Nucletron Company.

RESULTS

As it has been explained earlier, different holders were used for the vaginal applicator used in LDR Selectron, due to different vaginal sizes. The configuration of dummies used in a special setting could be changed. The measurements for the main settings at different distances from applicators are shown in table 3. The experimental results and the error in comparison with the TLD data obtained from manual of selectron system are also shown in this table.

As it can be seen from table 3, maximum air kerma rate constant was resulted by dummies arrangements of sixth setup, and it was found to be 919.3 μGyh⁻¹m². Minimum value was obtained for the first setup, and it was found to be 133.9 μGyh⁻¹m². For the

Table 3. The experimental results and error in comparison with TLD data.

Setup number	Number of active sources	Number of dummy	Distance from sources (cm)	Exposure rate constant (Rcm ² h ⁻¹ mCi ⁻¹)	Air Kerma rate constant (μGyh ⁻¹ m ²)	Dose rate correction in water (cGyh ⁻¹ mCi ⁻¹)	Mean differences from experiment (%)
1	2	3	2.0	3.54	133.9	3.3	2.3
2	3	3	2.5	4.01	228.1	3.2	3.0
3	4	7	3.0	3.34	253.2	2.7	2.0
4	8	4	3.5	3.20	483.8	4.3	3.7
5	10	3	4.0	3.50	661.0	2.5	3.3
6	14	4	4.5	3.47	919.3	2.1	0.6

exposure rate constant, maximum and minimum values were 4.01 Rcm²h⁻¹mCi⁻¹ and 3.2 Rcm²h⁻¹mCi⁻¹, for the second and fourth setups, respectively. The maximum value for dose rate constant was obtained for the fourth setup as 4.3 cGyh⁻¹mCi⁻¹. The minimum value for this parameter was obtained for the sixth setup to be 2.1 cGyh⁻¹mCi⁻¹. The radial dose at holder surface as obtained for first setup was 3.2 cGyh⁻¹mCi⁻¹. By the way, the minimum dose at the holder's surface for the sixth setup to be 0.6 cGyh⁻¹mCi⁻¹.

The maximum and minimum differences between Monte Carlo method and experimental results were obtained for the fourth (%3.7) and sixth (%0.6) setups, respectively.

DISCUSSION

In this study, dosimetric information was taken for different configuration of ¹³⁷Cs sources for selectron LDR brachytherapy system in Seyed Al-Shohada hospital of Isfahan, Iran. As mentioned earlier, mean difference between Monte Carlo method and experimental data was less than %5. The error was much less than what reported by Williamson *et al.* (7). The results approved the power and reliability of Monte Carlo method in dosimetric calculation in brachytherapy sources.

Perez *et al.* (5) obtained dose rate constant for two types of afterloading brachytherapy sources of CDC-1 and CDC-3 manufactured by Amersham Company. They found dose rate constant of 1.13±0.003 cGym²h⁻¹ and

1.103±0.003 cGym²h⁻¹ for the first and second sources (5). Casal *et al.* (6) reported the dose rate of 0.946±0.007 cGym²h⁻¹ around the source on CDCS-M-type source, used in LDR afterloading system. Williamson *et al.* (7) also obtained dose distribution around the two types of ¹³⁷Cs sources (3M6500, CDCS.J). They used the Monte Carlo MCPT code for simulation and their results for dose rate constant was 0.978 cGym²h⁻¹, and 0.973 cGym²h⁻¹ for the two sources, respectively. The comparison of their results with the results of TLD dosimetry had shown an error of %5 (7).

The reason for these differences among the results obtained in the present study with what achieved in the related literature may be due to error in experimental dosimetry, uncertainly in sources activity, and uncertainly in mass energy attenuation coefficient.

In conclusion these findings showed the possible application of ¹³⁷Cs afterloading LDR Selectron system for brachytherapy, in particular, for the treatment of vaginal cancer. The findings also indicated that the Monte Carlo simulation method could be useful for determining dosimetric characteristics of brachytherapy sources in particular ¹³⁷Cs sources.

REFERENCES

- Ghiassi-nejad M (2000) Dosimetric characteristics of ¹⁹²Ir sources used in interstitial brachytherapy. *Applied Radiation and Isotopes*, **55**: 189-195.
- Nath R, Anderson LL, Luxton G, Weaver KA, Williamson JF, Meigooni AS (1995) Dosimetry of interstitial brachytherapy source: recommendation of AAPM

- Radiation Therapy Committee Task Group No. 43. *Med Phys*, **22**: 209.
3. Cameron JR, Suntharalingam N, Kenney GN (1968) Thermoluminescent Dosimetry. Madison WI: The University of Wisconsin Press, USA.
 4. Spanier J, Gelbard EM (1996) Monte Carlo principles and neutron transport problems. *Addition Wesley, Reading, Mass*, 135.
 5. Perez CJ (2002) Dosimetric characteristics of the CDC type miniature cylindrical ^{137}Cs brachytherapy sources. *Med Phys*, **29**: 538-543.
 6. Casal E (2000) Monte Carlo calculation of dose rate distribution around the amersham CDCS-M-type ^{137}Cs source. *Med Phys*, **27**: 132-139.
 7. Williamson JF (1998) Monte Carlo based dose-rate tables for the amersham CDCS. J and 3M model 6500 ^{137}Cs tubes. *Int J Radiat Oncol Biol Phys*, **41**: 959-970.
 8. Briesmeister JF (2000) A General Monte Carlo N-Particle Transport Code. Los Alamos National Laboratory Report LA-12625-M Version 4C.
 9. Perez J, Ballester F (2001) Monte Carlo calculation of dose rate distribution around the walstam CDC-K-type ^{137}Cs sources. *Phys Med Biol*, **46**: 2029-2040.
 10. Khan FM (1994) The Physics of Radiation Therapy. Williams & Wilkins, USA.